

Features

- LED driving current up to 1A
- High efficiency up to 92%
- Operating input voltage up to 48V
- High switching frequency up to 500kHz
- PWM/DC input for dimming control
- Built-in output open-circuit protection
- SOP-8L, SOP-8L-EP and DFN3030-10 are available in "Green" Molding Compound (No Br, Sb)
- Lead Free Finish/RoHS Compliant (Note 1)

General Description

The AP8802 is a step-down DC/DC converter designed to drive LEDs with a constant current. The device can drive up to thirteen LEDs, depending on the forward voltage of the LEDs, in series from a voltage source of 8V to 48V. Series connection of the LEDs provides identical LED currents resulting in uniform brightness and eliminating the need for ballast resistors. The AP8802 switches at frequency up to 500kHz. This allows the use of small size external components, hence minimizing the PCB area needed.

Maximum output current of AP8802 is set via an external resistor connected between the V_{IN} and SET input pins. Dimming is achieved by applying either a DC voltage or a PWM signal at the CTRL input pin. An input voltage of 0.2V or lower at CTRL shuts down the output at SW and puts the device into a low-current standby state.

Applications

- Commercial & industrial lighting
- Small LCD panel backlight
- Appliances interior lighting
- Architecture Detail lighting

Typical Application Circuit

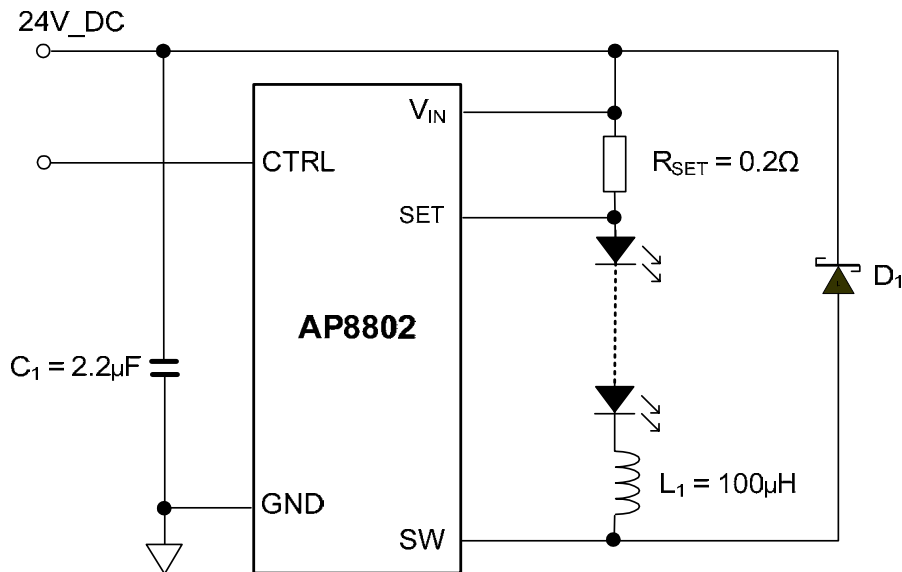
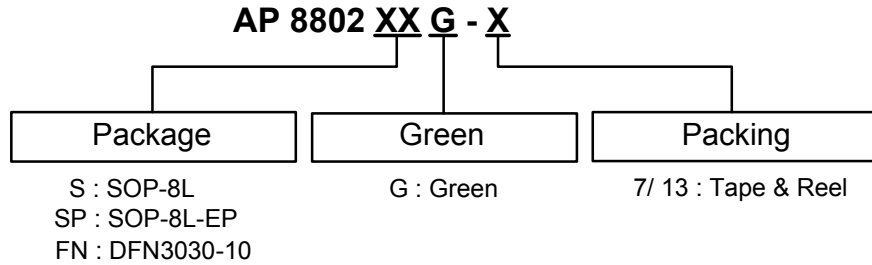

Figure 2: Typical Application Circuit

Ordering Information



Device	Package Code	Packaging (Note 2)	7"/13" Tape and Reel	
			Quantity	Part Number Suffix
AP8802SG-13	S	SOP-8L	2500/Tape & Reel	-13
AP8802SPG-13	SP	SOP-8L-EP	2500/Tape & Reel	-13
AP8802FNG-7	FN	DFN3030-10	3000/Tape & Reel	-7

- Notes:
1. EU Directive 2002/95/EC (RoHS). All applicable RoHS exemptions applied. Please visit our website at http://www.diodes.com/products/lead_free.html.
 2. Pad layout as shown on Diodes Inc. suggested pad layout document AP02001, which can be found on our website at <http://www.diodes.com/datasheets/ap02001.pdf>.

Pin Assignments

(1) SOP-8L

(Top View)

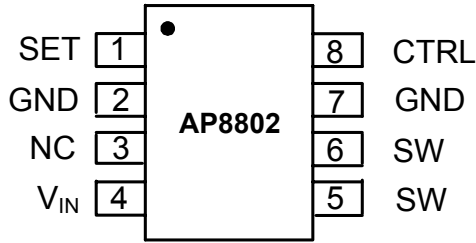

(2) SOP-8L-EP

(Top View)

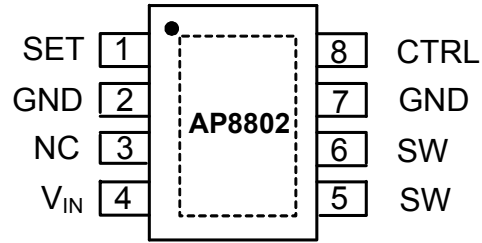

(3) DFN3030-10

(Top View)

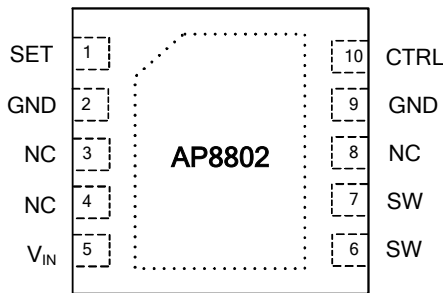

Pin Descriptions

Pin Name	Description
SW	Switch Pin. Connect inductor/freewheeling diode here, minimizing track length at this pin to reduce EMI.
GND	GND pin
SET	Set Nominal Output Current Pin. Configure the output current of the device.
CTRL	Dimming and On/Off Control Input. Input voltage of 0.2V or lower forces the device into low current standby mode and shut off the output. A PWM signal allows the output current to be adjusted above or below the level set by the resistor connected to SET input pin. The input impedance is about 50kΩ, and if the pin is left open $V_{CTRL} = V_{REF}$
V_{IN}	Input Supply Pin. Must be locally bypassed.
NC	No connection

Block Diagram

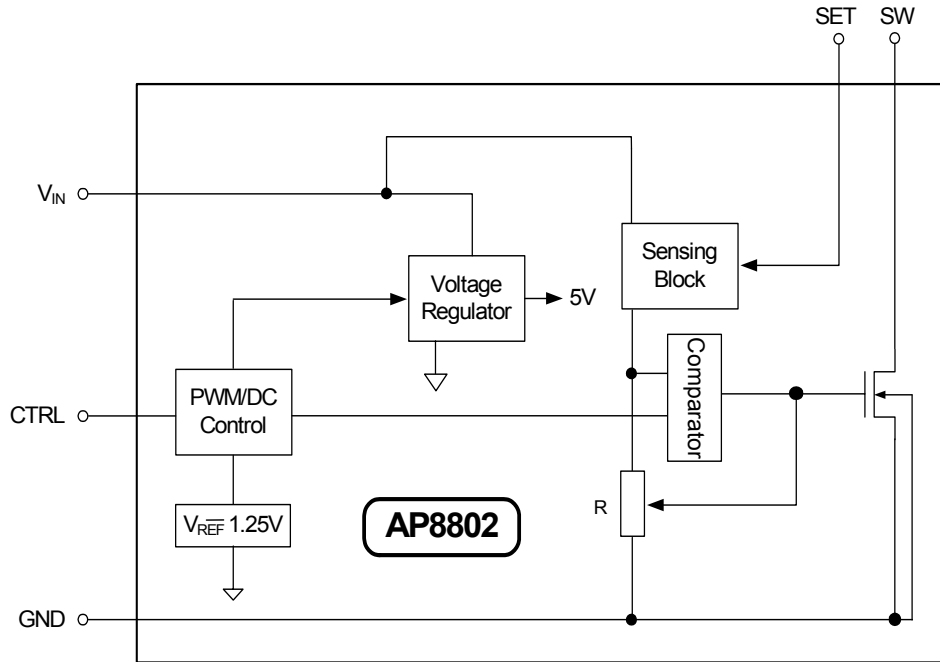

Figure 1: AP8802 block diagram

Absolute Maximum Ratings

Symbol	Parameter	Rating	Unit
V_{IN}	VIN pin voltage	-0.3~50	V
V_{SW}	SW voltage	-0.3~50	V
T_J	Junction Temperature	150	°C
T_{LEAD}	Lead Temperature Soldering	300	°C
T_{ST}	Storage Temperature Range	-65 to +150	°C

Caution: The absolute maximum ratings are rated values exceeding which the product could suffer physical damage. These values must therefore not be exceeded under any condition.

Semiconductor devices are ESD sensitive and may be damaged by exposure to ESD events. Suitable ESD precautions should be taken when handling and transporting these devices

Recommended Operating Conditions

Symbol	Parameter	Min	Max	Unit
T_A	Ambient Temperature Range	-40	105	°C

Electrical Characteristics ($V_{IN}=12V$, $T_A=25^{\circ}C$, unless otherwise specified)

Symbol	Parameter	Conditions	Min	Typ.	Max	Unit
V_{IN}	Operating Input Voltage		8.0	-	48	V
I_{OUT}	Continuous switch current	(Note 3)			1	A
I_Q	Quiescent Current		-	75	120	μA
F_{OSC}	Switching Frequency		-	-	0.5	MHz
V_{THD}	Internal Threshold Voltage		184	200	216	mV
V_{REF}	Internal Reference Voltage		-	1.25	-	V
SET	SET pin input current	$V_{SET}=V_{IN}-0.2$	-	5	-	μA
$R_{ds(on)}$	On Resistance of MOSFET	$I_{SW}=0.8A$		0.65	1.1	Ω
$I_{SW\ Leakage}$	Switch leakage current		-	-	8	μA
EN	Voltage High	ON	1.25	-	-	V
EN	Voltage Low	OFF	-	-	0.2	V
θ_{JA}	Thermal Resistance Junction-to-Ambient	SOP-8L (Note 4)	-	82	-	$^{\circ}C/W$
		SOP-8L-EP (Note 4)	-	45	-	$^{\circ}C/W$
		DFN3030-10 (Note 4)	-	38	-	$^{\circ}C/W$
θ_{JC}	Thermal Resistance Junction-to-Case	SOP-8L (Note 4)	-	52	-	$^{\circ}C/W$
		SOP-8L-EP (Note 4)	-	7	-	$^{\circ}C/W$
		DFN3030-10 (Note 4)	-	24	-	$^{\circ}C/W$

Notes: 3. Refer to figure 7 for the device derating curve.
 4. Test condition for SOP-8L, SOP-8L-EP and DFN3030-10: Device mounted on FR-4 PCB, 2"x2", 2oz copper, minimum recommended pad layout on top layer and thermal vias to bottom layer ground plane. For better thermal performance, larger copper pad for heat-sink is needed.

Application Information

LED Current Control

The LED current is controlled by the resistor RSET in Figure 2. Connected between VIN and SET the nominal average output current in the LED(s) is defined as:

$$I_{LED} = \frac{V_{THD}}{R_{SET}}$$

If the CTRL pin is driven by an external voltage (lower than 2.5V), the average LED current is:

$$I_{LED} = \frac{V_{CTRL}}{V_{REF}} \frac{V_{THD}}{R_{SET}}$$

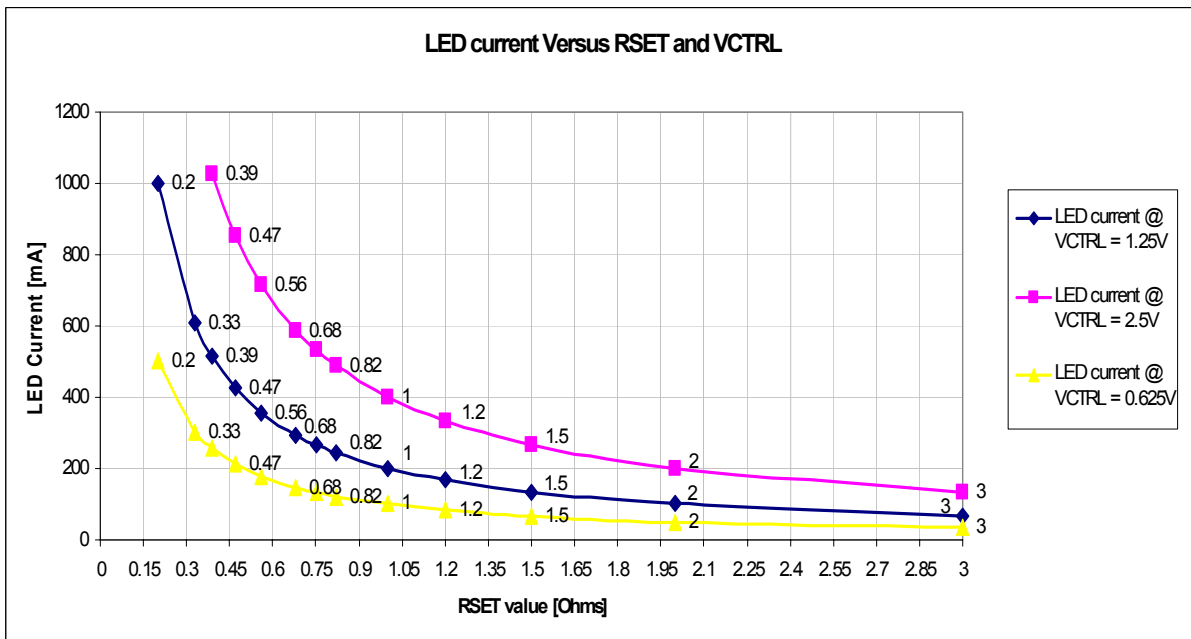

Figure 3: LED Current setting Vs RSET and VCTRL

Application Information (Continued)

Inductor Selection

This section highlights how to select the inductor suitable for the application requirements, in terms of switching frequency, LED current accuracy and temperature.

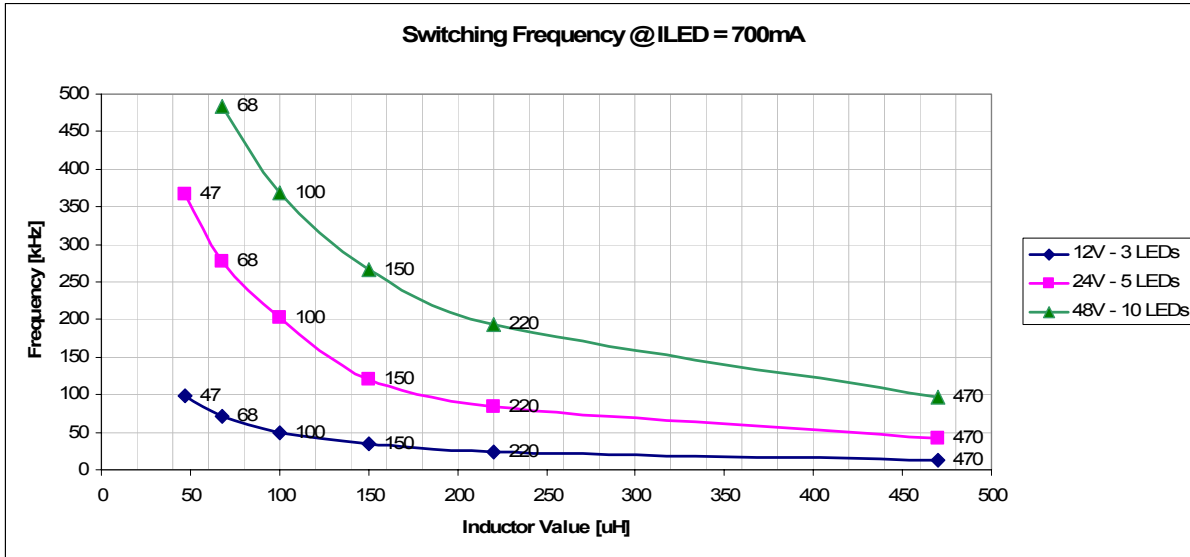

Figure 4: Switching Frequency Vs Inductor Value

The inductor influences the LED current accuracy that the system is able to provide. The following section highlights how to select the inductor in relation to the device packages and the LED current, while maintaining the chip temperature below 70°C.

Application Information (Continued)

AP8802 DFN3030-10 Minimum Recommended Inductor - LED Current 1A
8% Accuracy, <70°C Case Temperature

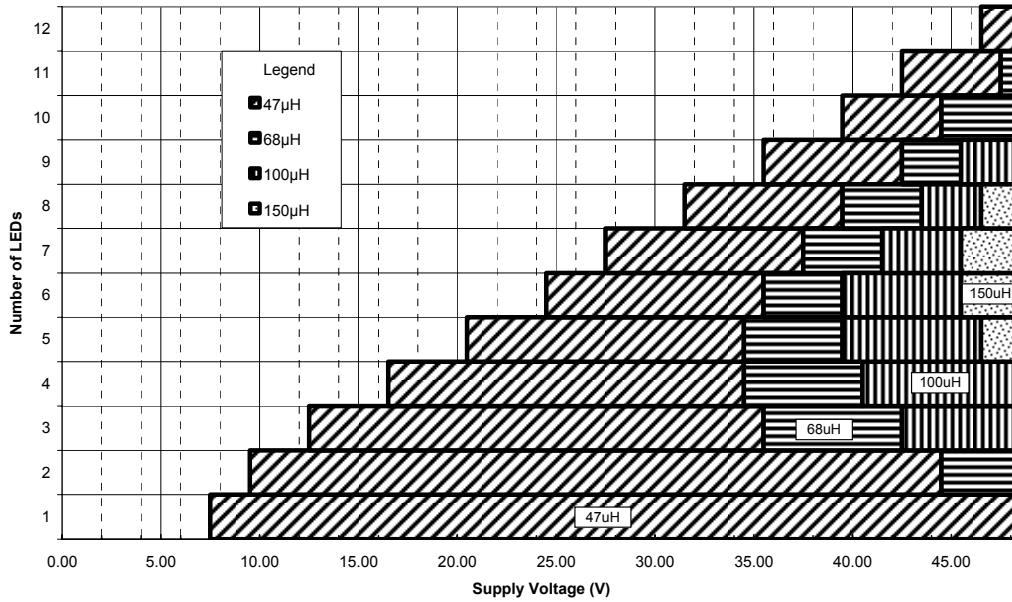

Figure 5: DFN3030-10 recommended inductor with 1A LED current

AP8802 SOP8EP Minimum Recommended Inductor
8% Accuracy, <70°C Case Temperature, 1A Target Current

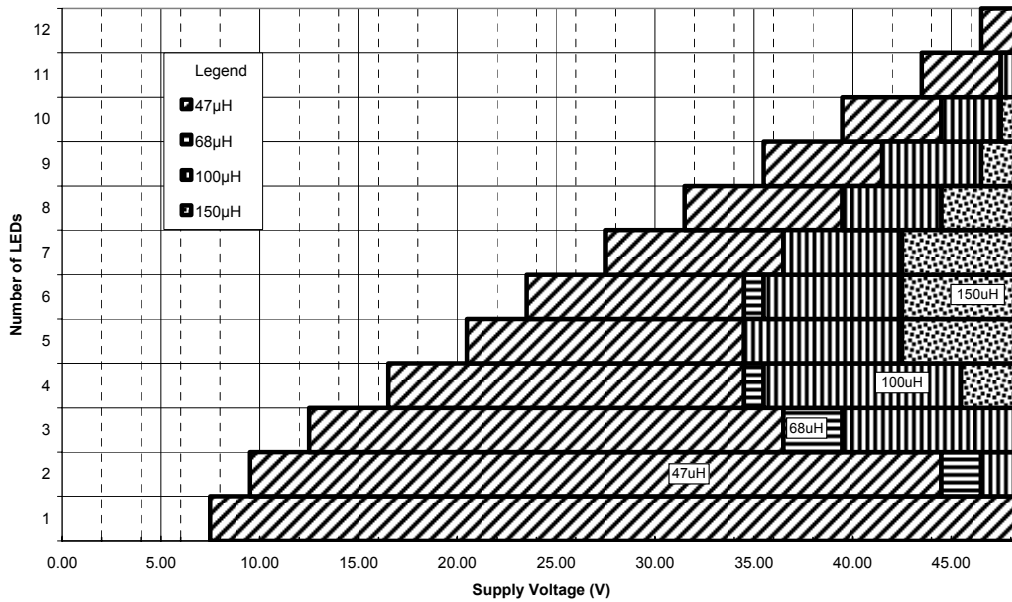

Figure 6: SOP8L-EP recommended inductor with 1A LED current

Application Information (Continued)

AP8802 SOP-8L Minimum Recommended Inductor
8% Accuracy, <70°C Case Temperature

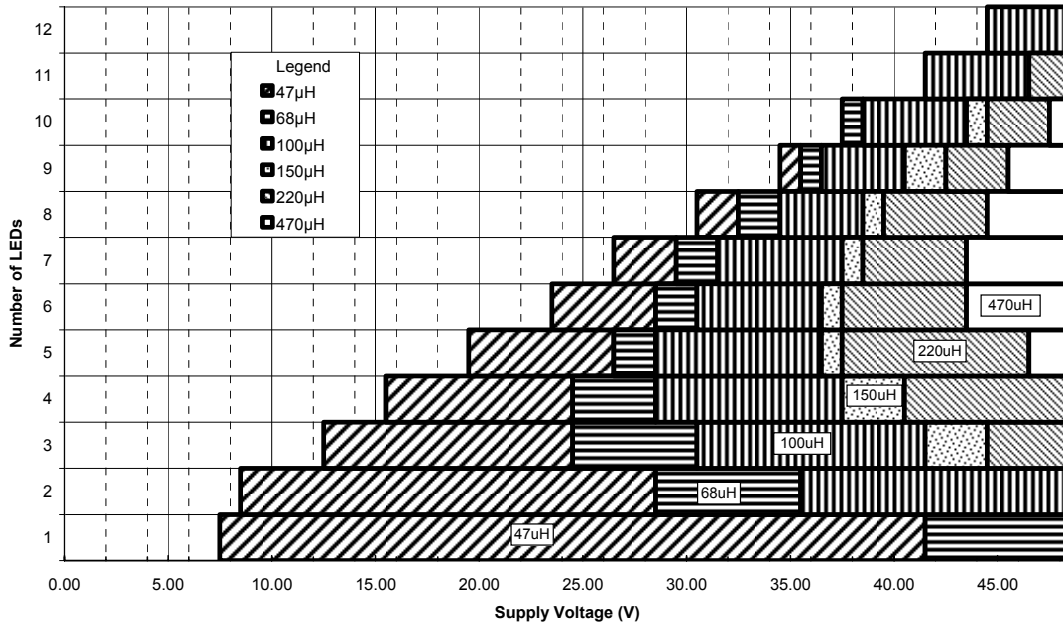

Figure 7: SOP-8L recommended inductor with 700mA LED current

Application Information (Continued)

Capacitor Selection

The small size of ceramic capacitors makes them ideal for AP8802 applications. X5R and X7R types are recommended because they retain their capacitance over wider voltage and temperature ranges than other types such as Z5U. A 2.2µF input capacitor is sufficient for most intended applications of AP8802. A 4.7µF input capacitor is suggested for application with an input voltage equal or higher than 40V.

Diode Selection

Schottky diodes, e.g. B2100 or B1100, with their low forward voltage drop and fast reverse recovery, are the ideal choice for AP8802 applications.

PWM Dimming

A Pulse Width Modulated (PWM) signal with a max resolution of 8bit, can be applied to the CTRL pin to change the output current to a value above or below the nominal average value set by resistor RSET. To achieve this resolution the PWM frequency has to be lower than 500Hz.

Thermal Considerations

The graph below in figure 8, gives details for power derating. This assumes the device to be mounted on a 25x25mm PCB with 1oz copper standing in still air.

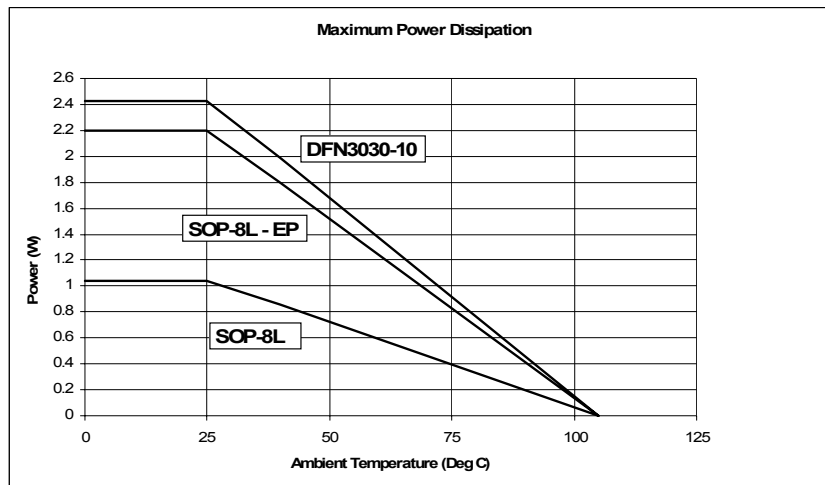

Figure 8: AP8802 derating curves

Package Selection

The device comes with a wide selection of packages. The suggested package is able to provide a case temperature below 70°C (with an ambient temperature of 25°C) for the combination of input voltage and load requested.

Application Information (Continued)

AP8802 - suggested package @
ILED=1A and 100µH Inductor

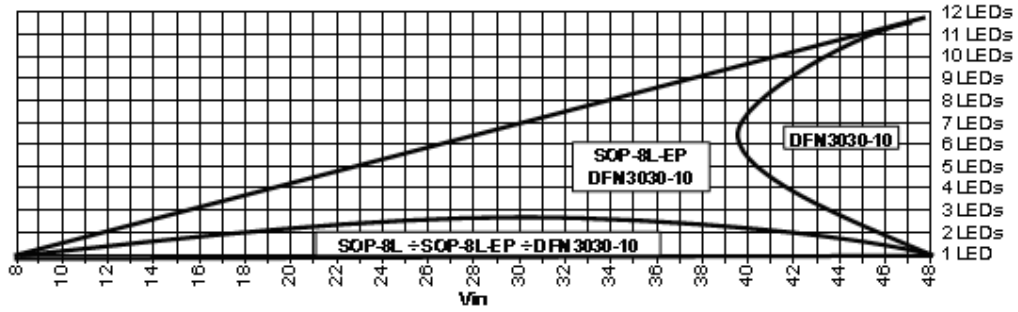

Figure 9: Suggested package for a 1A application

AP8802 - suggested package @
ILED=700mA and 100µH Inductor

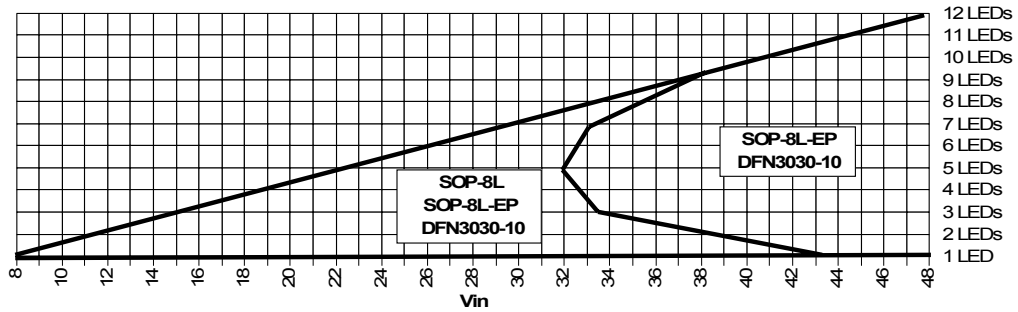
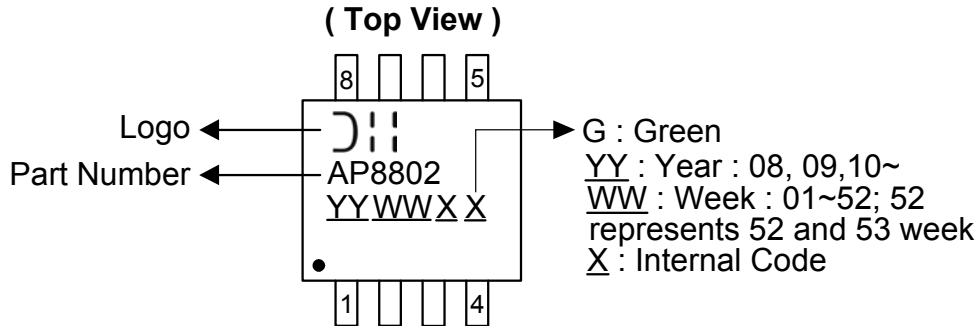

Figure 10: Suggested package for a 700mA application

Marking Information

(1) SOP-8L



(2) SOP-8L-EP

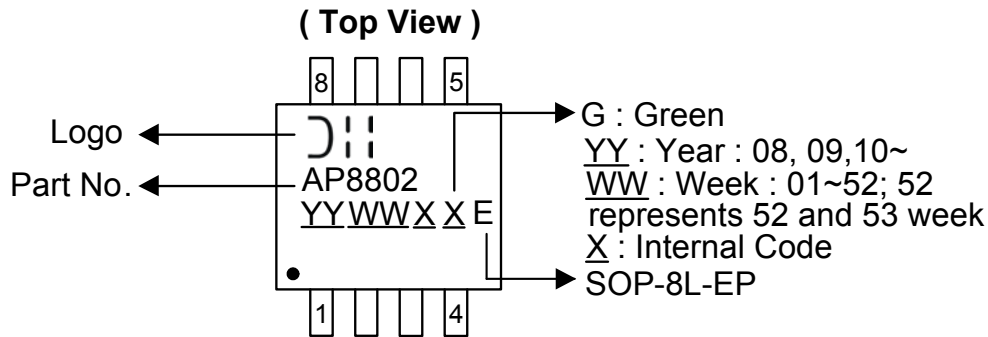

(3) DFN3030-10

(Top View)

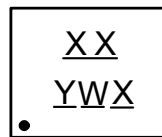

XX : Identification Code
Y : Year : 0~9
W : Week : A~Z : 1~26 week;
a~z : 27~52 week; z represents 52 and 53 week
X : A~Z : Green

Part Number	Package	Identification Code
AP8802FNG-7	DFN3030-10	A5

Package Information (All Dimensions in mm)

(1) Package Type: SOP-8L

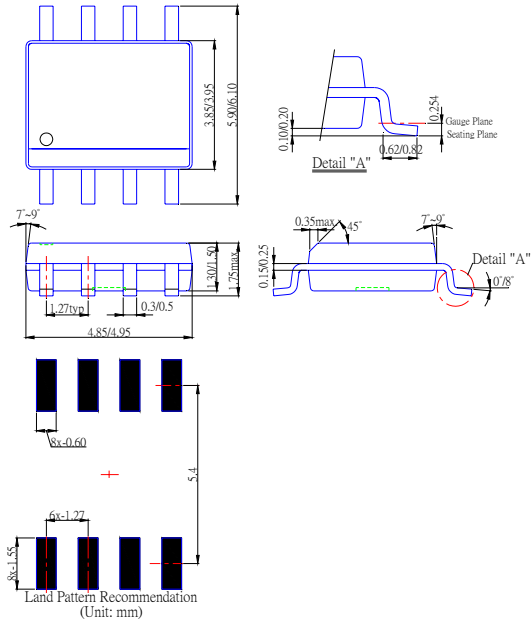

(2) Package Type: SOP-8L-EP

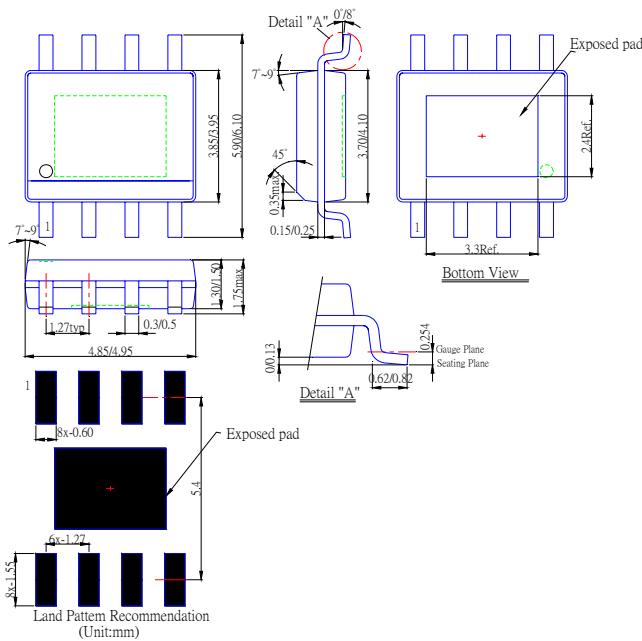

Package Information (Continued)

(3) Package Type: DFN3030-10

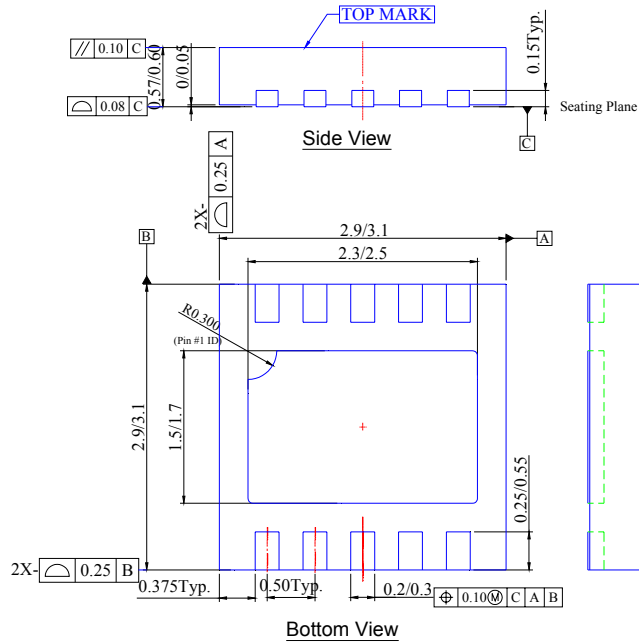

Taping Orientation

For DFN3030-10

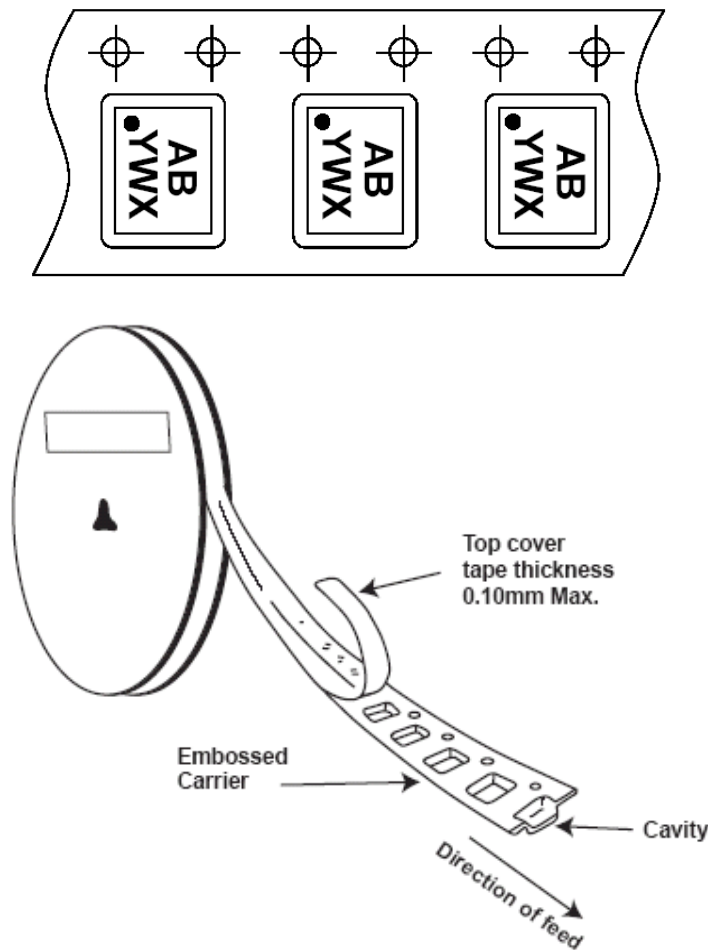

Notes: 5. The taping orientation of the other package type can be found on our website at <http://www.diodes.com/datasheets/ap02007.pdf>.

IMPORTANT NOTICE

Diodes Incorporated and its subsidiaries reserve the right to make modifications, enhancements, improvements, corrections or other changes without further notice to any product herein. Diodes Incorporated does not assume any liability arising out of the application or use of any product described herein; neither does it convey any license under its patent rights, nor the rights of others. The user of products in such applications shall assume all risks of such use and will agree to hold Diodes Incorporated and all the companies whose products are represented on our website, harmless against all damages.

LIFE SUPPORT

Diodes Incorporated products are not authorized for use as critical components in life support devices or systems without the expressed written approval of the President of Diodes Incorporated.